

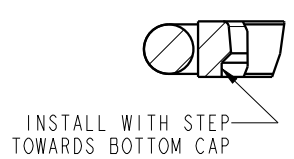

NO	QTY	DESCRIPTION	MODEL NUMBER L1-4125-00-X-US	STANDARD SEAL KIT
1	1	NUT, JAM, HEX, M8-1.00	21-5100-00	
2	3	SPRING, COMPRESSION	23-3500-85	X
3	3	BALL, TUNGSTEN-CARBIDE, 4mm	23-6500-09	X
4	2	O-RING (6mm X 1)	39-0510-79	X
5	1	O-RING (26mm X 2)	39-0510-81	X
6	2	O-RING (4mm X 3)	39-0510-87	X
7	1	SEAL, WIPER, SNAP IN, WED, 15, 94A, AU	39-0530-41	X
8	1	SEAL, STEP, ROD, 15	39-0560-01	X
9	1	SEAL, CAP, PISTON, 25, 90A, AU GRPHT FLD	39-0560-21	X
10	2	PLUG, SOCH, G1/8	43-0680-04	
11	1	PLUNGER, LEFT HAND (SHOWN)	81-4001-31	
	1	PLUNGER, RIGHT HAND	81-4001-41	
	1	PLUNGER, STRAIGHT	81-4001-21	
12	1	CAP, LC/SC, 7MPa, 25B	81-4001-51	
13	2	PLUG, MANIFOLD, 7MPa, M6	81-4002-00	
14	3	PIN, STOP ,BALL, METRIC, 4mm BALL	81-4002-02	X
15	1	SENSOR, ULTRASONIC, M12, 1m	29-7402-00	
16	1	SENSOR, FACE SEAL	43-0000-40	
N/A	N/A	SEAL KIT (STANDARD)	L6-0142-50	NOTED

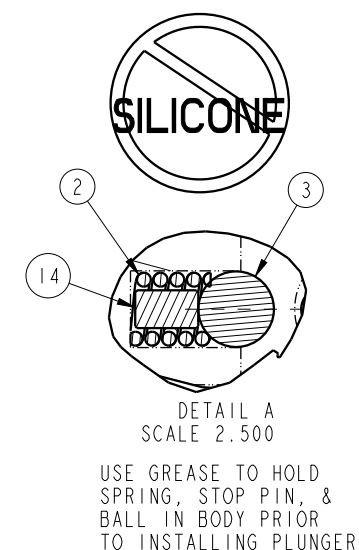
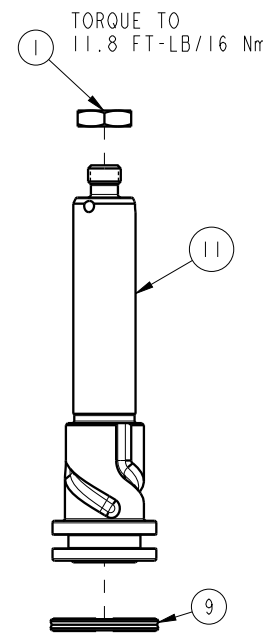
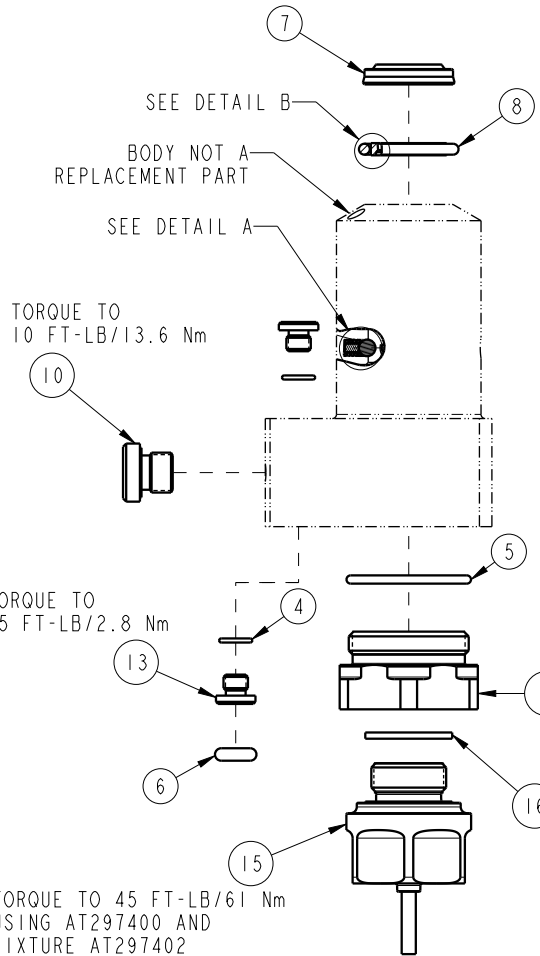

DETAIL B  
SCALE 2.500

TORQUE TO 45 FT-LB/61 Nm  
USING AT297400 AND  
FIXTURE AT297402  
BEFORE ASSEMBLING  
THE RETAINER

TORQUE TO  
20 FT-LB/27 Nm  
USING AT297401

<b>PARTS LIST</b>	 VEKTEK, INC. 1334 E. SIXTH AVE. P.O. BOX 625 EMPORIA, KS. 66801 U.S.A.	
	ASSEMBLIES AFFECTED	PARTS LIST, ASSY, SC, BF, 7MPa, 25B
REV	DATE	SIZE
DATE: 7/28/25		A
DRAWING STATUS: <b>Released</b>		REV
PRODUCTION APPROVED FOR RELEASED STATUS ONLY		A

A	5779	RELEASE	ALS	7/29/25
REV	IN ACCORDANCE WITH ECN	EFFECTIVE DATE	REVISED BY	DATE